

System Requirements for Mini-MOST Experiment

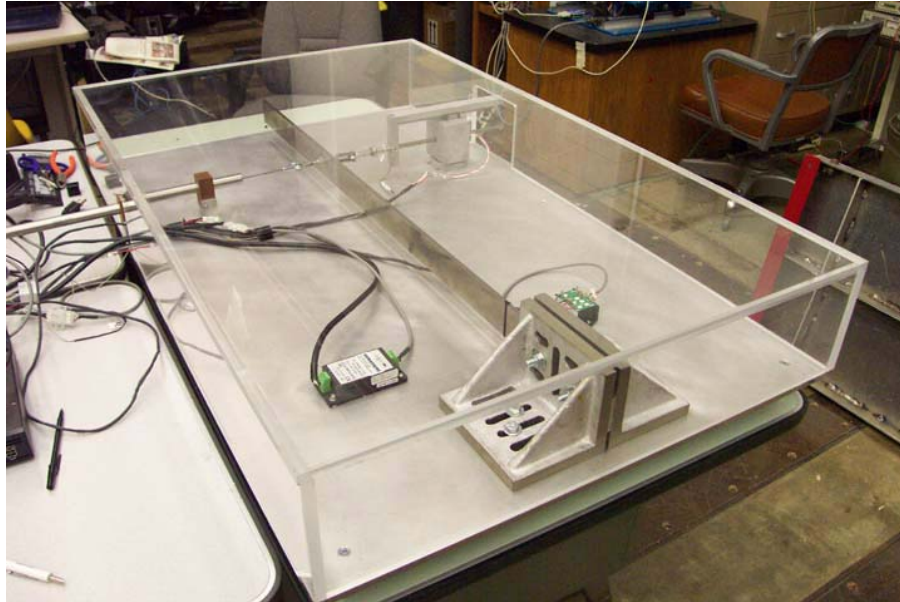

Narutoshi Nakata¹(nakata@uiuc.edu)

Guangqiang Yang¹(gyang2@uiuc.edu)

Billie F. Spencer, Jr.¹(bfs@uiuc.edu)

¹UIUC MUST-SIM Facility, Urbana, IL



1. Introduction

The main purpose of the Mini-MOST experiment is to show the capability of major NEESgrid service components using a small-scale physical experiment setup. Comparing with the Multi-site Online Simulation Test (MOST) conducted on July 30, 2003, the Mini-MOST experimental hardware, as implied by its name, is small in size and can be easily packed and shipped to other places. However, the software involved in this experiment is similar to what was used for the MOST experiment and provides the same level of functionality and services. Therefore, Mini-MOST experiment provides a desirable platform for students and researchers to be familiar with the NEESgrid software and to gain first-hand experience before conducting full-scale experiment. Moreover, the Mini-MOST experiment can also be utilized for the purposes of educational demonstration and software installation debugging.

This document provides some brief background information on the employed multi-site online simulation test scheme and detail description of hardware and software requirements for the Mini-MOST experiment.

2. Multi-Site Online Simulation Test

Figure 1 shows the schematic of the multi-site online simulation test scheme. In this modular framework, four distinct modules are included:

- Simulation Coordinator
- Master Computational Module

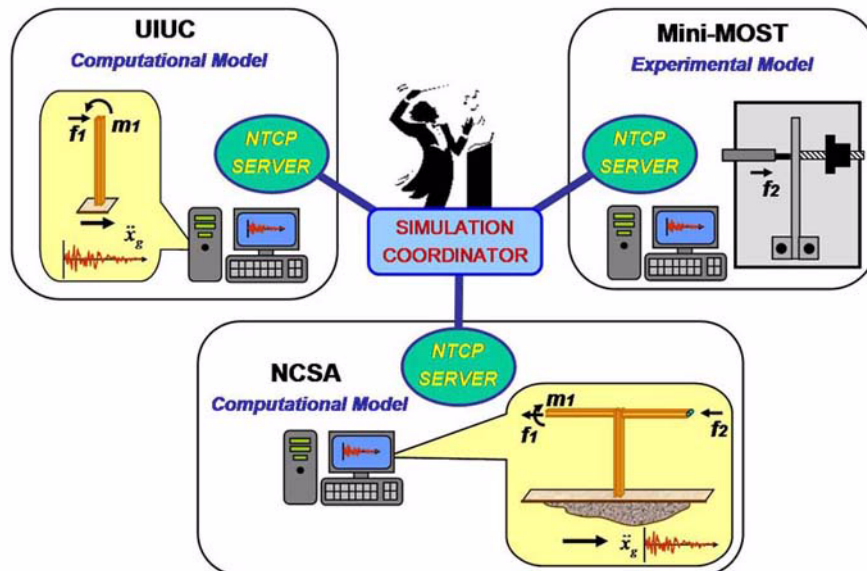

Figure 1. Schematic of the Multi-Site Online Simulation Test Scheme.



- Slave Computational Module
- Experimental Module

In the center of this scheme, it is the Simulation Coordinator (SC) which acts as the command center for the overall experiment. The SC sends the requests for specific action to and receives replies from individual module through NEESgrid Tele-Operation Control Protocol (NTCP) and a plug-in interface (more information regarding NTCP can be found at <http://www.neesgrid.org/news/documents.php>). This architecture provides great flexibility allowing each module to run in geographically remote locations and only requiring each module to interface with SC through NTCP.

The master computational module (NCSA) performs the numerical integration, combining results from the experimental (Mini-MOST) and slave computational node (UIUC). At each time step, the master computational module numerically calculates the frame's response and send the target displacement and rotation at the substructure connection points to the SC through NTCP. It waits until receiving the measured force and moment response from experimental and/or slave computational modules before the numerical integration proceeds. The integration scheme used in the simulation is an alpha-operator splitting method.

The unique feature for this framework is the interchangeability between the experimental and slave computational modules. Therefore, experiments can be debugged using the computational modules, minimizing the risk of unexpected damage to the physical structure/hardware.

The data collected during the experiment is saved in the local data storage and/or transferred in real-time to the central repository in the local NEESPOP using Samba. Once the data is in the central repository, remote observers can view the experimental data using various visualization tools within the web-based CHEF environment. Tele-observation is one of the main features of the NEESgrid services.

3. Hardware Requirements

Figure 2 provides an overhead view of the Mini-MOST experiment. The hardware of this experiment can be basically divided into three categories: specimen experimental setup, computers and instrumentation.

3.1 Specimen Experimental Setup

The test specimen for the Mini-MOST experiment is a steel beam with a rectangular cross section (as shown in Fig. 3a). The length of the beam is 40 inches with a width of 0.4 inches and height of 2 inches. The beam is fixed at one end by two L-shaped anchorages, as shown in Fig. 3b.

The whole experiment is mounted on a 48 by 30 inch (standard size for the computer desk) aluminum base plate. The base plate has 4 fixed legs at the each corner and 2 adjustable legs in the middle to keep it level and prevent bending.



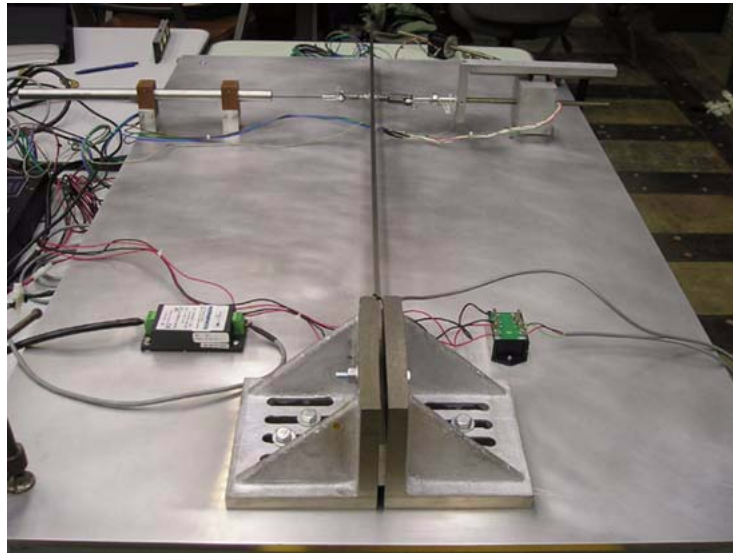
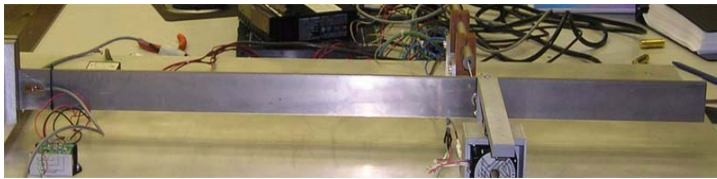

Figure 2. Overhead View of the Mini-MOST Experiment.

(a)



(b)

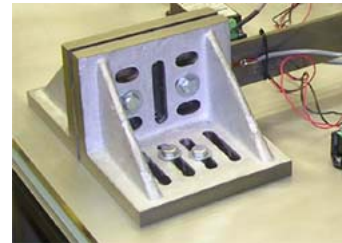

Figure 3. (a) Steel Beam; (b) L-Shape Anchorages.

To eliminate the rotational motion of the stepper motor lead screw, an anti-spin mechanism using linear guide is designed and installed. With this mechanism, only translational motion of the lead screw is allowed. To minimize the lateral load on the load cell, a pivot mechanism and bearing are installed between the load cell and beam and between the motor box and base plate, respectively. Moreover, a similar pivot mechanism is also utilized between the LVDT and beam such that only the lateral deformation of the beam is measured. Detailed plans for the experimental design will be reported in another document and is currently being written.

3.2 Computers

3.2.1 Mini-MOST Computer

The Mini-MOST computer is used for stepper motor control and data acquisition, as well as NTCP communication between the Mini-MOST and Simulation Coordinator. It is desirable that the computer is installed with Windows XP operating system and has a minimum 2.0 GHz



CPU speed, 512 MB memory, 80 GB hard drive and 2 PCI slots.

3.2.2 *Simulation Computers*

The simulation computers are utilized to simulate the frame response numerically. The simulation code is written in MATLAB 6.5. During the experiment, at least one simulation computer is required to run the master computational module. However, when multiple computational nodes are involved, you have the option of running both master and slave computational modules in one computer or in separated computers. Simulation computers need to have a minimum 1 GHz CPU speed, 256 MB memory and are installed with MATLAB 6.5. If the simulation becomes complicated, the computer configuration needs to be upgraded accordingly.

3.2.3 *NEESpop Server*

NEESpop is a Linux server installed with NEESgrid software to provide essential services for the experiment. This software package includes CHEF, grid services, NTCP, etc. The server must have a minimum 1 GHz CPU speed with dual processors, 1GB RAM, 2 PCI slots, 36 GB SCSI hard disk, dual gigabit ethernet cards, and be installed with Redhat Linux 7.2 or 7.3. The current NEESgrid software (release 2.2) can be downloaded at <http://neesgrid.org/software/neesgrid2.2/>.

3.2.4 *Optional Tele-Presence Server*

The tele-observation is optional for the Mini-MOST experiment. To achieve the tele-observation, a system installed with NEES tele-presence software needs to be employed. The minimum configuration for this Linux based system include 1 GHz CPU speed with dual processors, 1 GB RAM, 2 PCI slots, 36 GB SCSI disk, dual gigabit ethernet cards. In addition, you also need Axis 2401 Internet Appliance Video Server and tele-robotic camera with PZT capability. The tele-presence system can support up to 5 video servers and 5 video cameras at the same time.

3.3 Instrumentation

3.3.1 *HSI Size 23 Non-Captive Linear Actuator*

An HSI size 23 non-captive linear actuator is used to impose the desired displacement to the beam. This non-captive bipolar stepper motor has a 10-inch long lead screw, thus a ± 3 inch stroke. The travel per step is 0.002 inch, the input voltage is 5 volts DC, and maximum thrust force of 25 lb. To prevent the rotation of lead screw, an L-shape anti-spin mechanism is designed. As shown in Fig. 4, the stepper motor lead screw is fixed to the anti-spin mechanism

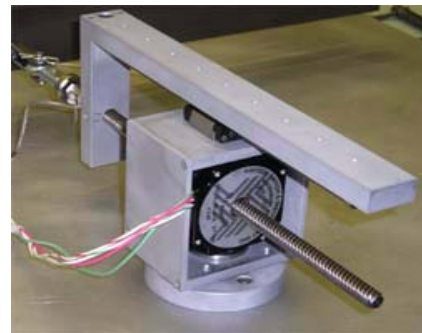

Figure 4. HSI Size 23 Non-Captive Bipolar Linear Actuator.



by a set screw. The anti-spin mechanism, in turn, connects to the motor box with a linear guide. This linear guide eliminates the rotational motion of the lead screw; thus, only translational motion is allowed. Moreover, a bearing is installed at the bottom of the motor box which allows the motor and anti-spin assembly to rotate in the horizontal plane thus minimizing the lateral force imposed on the load cell.

3.3.2 NI MID-7602 Servo Motor Drive

To drive the linear actuator, a National Instruments MID-7602 integrated stepper motor power drive (Fig. 5a) is employed. This micro-stepping enabled motor drive can control 2 stepper motors at the same time with a maximum current of 1.4 Amp/phase. In addition, this drive provides convenient connections for motion I/O signals and all features of a universal motion interface (UMI) wiring module.

3.3.3 NI PCI-7342 Motion Control Hardware

The National Instruments PCI-7342 board (Fig. 5b) provides the real-time control of the stepper motor using either digital encoder or external analog feedback. This hardware also supports motion linear interpolation, 32 bits of digital I/O for high-speed capture, and the RTSI bus for powerful real-time integration.

3.3.4 NI SHC68-C68-S Cable

This cable connects the PCI-7342 motion control hardware and MID-7602 stepper motor drive.



Figure 5. (a) MID-7602 Stepper Motor Drive; (b) PCI-7342 Motion Control Hardware.

3.3.5 NI PCI-6036E DAQ Board

The National Instruments PCI-6036E (Fig. 6a) is a 16-bit DAQ board with a maximum rate of 200 kilo samples/sec. The NI PCI-6036E has sixteen-channel analog inputs when it operates under single-end mode and two ± 10 volt analog outputs.



3.3.6 NI BNC-2110 BNC Connector Box

The BNC-2110 BNC connector box (Fig. 6b) is a shielded connector block with signal-labeled BNC connectors. The BNC-2110 connector block simplifies the connection of analog signals, some digital signals, and two user defined connections to the DAQ device.

3.3.7 NI SH68-68-EP, Shielded Cable, 1m

The SH68-68-EP 68-pin Shielded Cable connects the PCI-6036E DAQ board with the BNC-2110 BNC connector box.

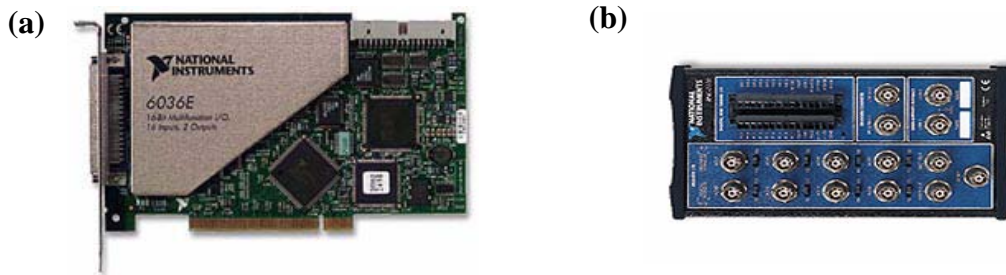

Figure 6. (a) PCI-6036E DAQ Board; (b) BNC-2110 BNC Connector Box.

3.3.8 Omega LC-201 Load Cell

To measure the restoring force of the beam, an Omega LC-201 load cell is used. This 25-lb load cell is a subminiature tension and compression strain-type force sensor with a diameter of 0.75". At 10-volt excitation, the load cell has a sensitivity of 1 mv/lb. To prevent the lateral force acting on the load cell, a pivot (as shown in Fig. 7) is installed between the beam and load cell in addition to the bearing installed at the bottom of the motor box.



Figure 7. Omega LC-201 Load Cell.

3.3.9 Strain Gauge

A standard strain gauge, as shown in Fig. 8, is attached at the end of the beam to measure the strain induced by the beam deformation. Although strain gauge measurement is not used for feedback and simulation, it is utilized as secondary measurement for load cell and LVDT reading verification and visualization.

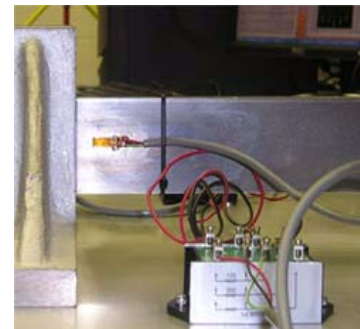

Figure 8. Strain Gauge and Bridge Completion Module.

3.3.10 Omega BCM-1 Strain Gauge Bridge Completion Module

The BCM-1 bridge completion module (Fig. 8) pro-



vides a convenient means of completing the Wheatstone Bridge circuit used for strain gauge measurement. The module can be used for quarter-bridge measurements with 120 or 350 Ohm gauges, or for half-bridges with gauges of any resistance.

3.3.11 Omega DP25B-S-A Strain Gauge Meter

Two Omega DP25B-S-A strain gauge meters (Fig. 9) are used in the Mini-MOST experiment. One meter is for load cell, and the other one is for strain gauge. The DP25B meters provide excitation voltages to sensors, read measurements back and amplify sensor signals before they are sent to the DAQ system. Moreover, the front LED panel of the meter can be configured to display sensor readings in physical unit. As shown in Fig. 9, the amber reading provides the load cell measurement in Newton, and the green reading gives the strain gage measurement in micro-strain.



Figure 9. Omega DP25B-S-A Strain Gauge Meter.

3.3.12 Schaevitz 3000 DC-EC LVDT, power supply and mounting block

The Schaevitz 3000 DC-EC Linear Variable Differential Transformer (LVDT), as shown in Fig. 10, is used to measure the displacement of the beam from the initial position. The stroke of this LVDT is ± 3 inch with a sensitivity of 3.33 volt/inch. The 15-volt excitation voltage is provided by a Schaevitz LVDT power supply. LVDT measurement is sent to both NI MID-7602 for displacement feedback control of the stepper motor and DAQ board.

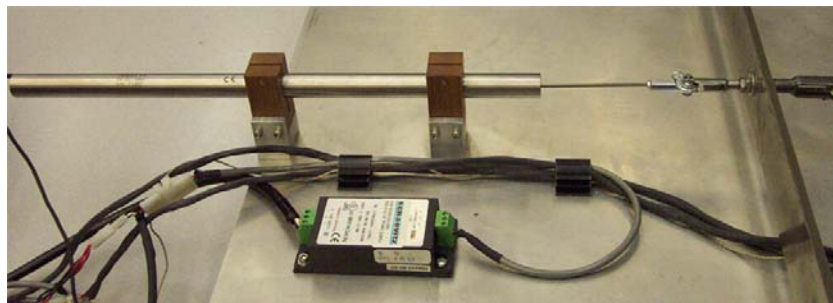

Figure 10. Schaevitz 3000 DC-EC LVDT.

4. Software Requirements

The Mini-MOST experiment is based on the several communication techniques. Figure 11 shows the NTCP architecture with the Mini-MOST experiment. As shown in the figure, communication between the SC and NTCP servers uses NEESgrid NTCP service. Communication between M plug-in and Matlab backend programs is OGSA based whereas communication



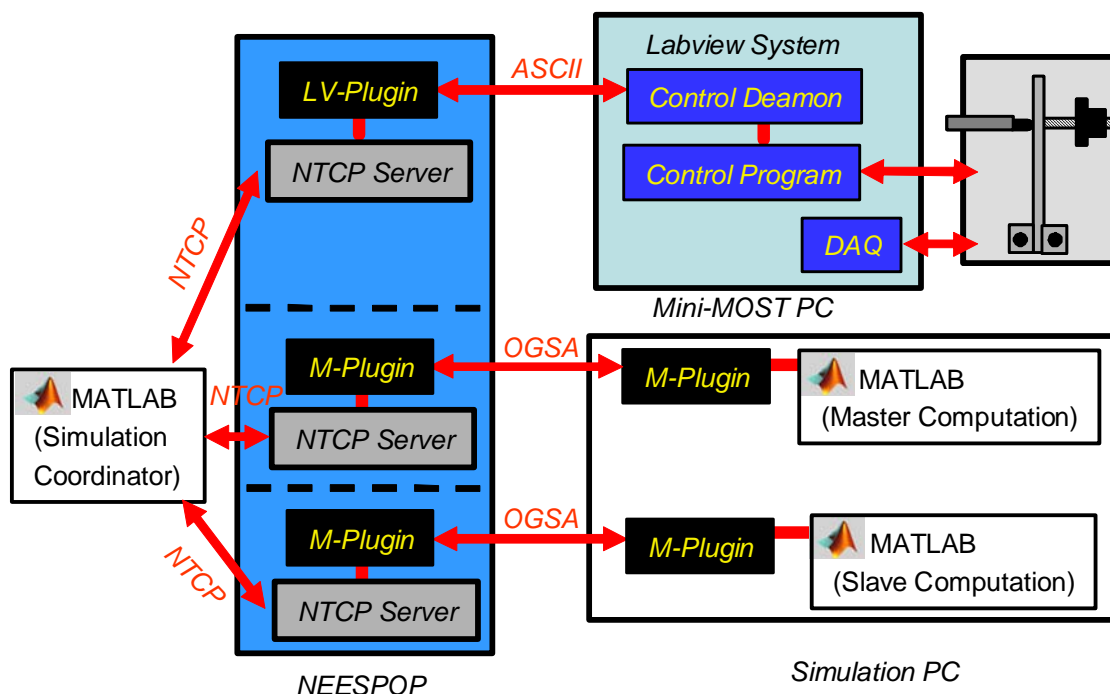

Figure 11. NTCP Architecture for the Mini-MOST Experiment.

between LV plug-in and ‘*Control daemon*’ is ASCII based. To implement all functionality, following software is required on each machine.

4.1 Mini-MOST Computer

- **LabVIEW Full Package:** The Mini-MOST experiment is running on the National Instruments LabView system. The main LabView programs for the Mini-MOST experiment include: ‘*Control Daemon*’ for communication with NEESpop, ‘*Control Program*’ for the stepper motor control and ‘*DAQ*’ for data acquisition of sensor data. These programs were developed by the NEESgrid System Integrator (SI) Team.
- **LabVIEW Internet Toolkit:** easily incorporate a variety of electronic communications capabilities, such as XML, CGI, and FTP transfers into your virtual instrumentation applications
- **NI Motion Assistant for Motion Control Programming:** a flexible and easy-to-use development tool for building and prototyping motion applications, gives you the ability to quickly develop motion control systems.

Mini-MOST LabVIEW software can be downloaded at the <http://www.neesgrid.org/software/neesgrid2.2> and detail instruction can be found at <http://www.mcs.anl.gov/neesgrid/mmost/>.



4.2 Simulation Computer

- **Matlab 6.5:** Matlab 6.5 is required to run the Matlab backend programs, 'NCSA_Comp_Site.m' and 'UIUC_Exp_Site.m'.
- **Simulation Software:** Matlab simulation code is required to run the SC, master and slave computational modules, etc. and can be downloaded at <http://www.neesgrid.org/software/neesgrid2.2>.
- **OGSA 3.0:** OGSA3.0 is required to set up the communication between Matlab backend programs and M plug-in on NEESpop. OGSA can be downloaded on the SI web site.
- **Java:** A Sun Java JDK or JRE version 1.3.1_01 or higher has to be installed. It can be downloaded at <http://java.sun.com/j2se/1.3/download.html>.
- **Ant:** The Ant build tool must be installed - version is 1.5.1 or greater. It can be downloaded at <http://apache.mirror.digitalspace.net/ant/binaries/apache-ant-1.5.3-1-bin.zip>.
- **Junit:** Junit has to be installed to run the tests. It can be downloaded at <http://prdownloads.sourceforge.net/junit/junit3.8.1.zip?download>.

4.3 NEESpop Server

- **NEESgrid 2.2:** NEESgrid 2.2 is required on NEESpop to employ the NTCP server program to communicate with the client, that is the SC in the Mini-MOST experiment.
- **Plug-ins:** Two plug-ins need to be installed: Matlab (M) plug-in and LabView (LV) Plug-in. M plug-in communicates between NTCP server and Matlab backend programs, 'NCSA_Comp_Site.m' and 'UIUC_Exp_Site.m'. LV plug-in interface is required for the communication between NTCP server and LabView backend program, 'Control Daemon'.

After all these software are installed, all software environments have to be properly configured referring to 'nees-ntcp-install-win'.

5. Conclusions

The NEESgrid architecture contains a substantial number of interacting components and services. Mini-MOST represents an inexpensive but comprehensive means for research programmers to interact with and learn these components without tying up more expensive or delicate research equipment. Because the software is a close counterpart to that of a full-scale NEES experiment – the MOST experiment of July, 2003 – Mini-MOST offers a working reference implementation of NEESgrid services, allowing NEES research programmers to see first-hand how the software and hardware components interact. It is anticipated that Mini-MOST will also



become part of the NEESgrid training materials being developed by NCSA for delivery to the NEES Consortium in 2004.



Table 1. Price List for the Mini-MOST Experimental Setup

| | Product Name | Part No. | Quantity | Price | Specification |
|---------------|---|-----------------|----------|---------------------|---|
| 1 | Dell Dimension 4600 DAQ Computer | | 1 | \$ 1,800.00 | DAQ PC with MS Windows OS and 3 PCI slots |
| 2 | NI MID-7602 Stepper Motor Drive ¹ | 778003-01 | 1 | 1,795.00 | 2-axis servo power drive, max 1.4A/phase, 24 volt output |
| | NI PCI-7342 Motion Control Hardware ¹ | 778665-02 | 1 | 895.00 | 2-axis motion controller for stepper or servo motors |
| | NI SHC68-C68-S Cable ¹ | 186380-02 | 1 | 150.00 | Cable connecting the MID-7652 and PCI-7342 |
| | NI PCI-6036E DAQ Board ¹ | 778465-01 | 1 | 745.00 | 200 kS/s, 16-bit, 16 SE analog input and 2 analog output |
| | NI BNC-2110 Connector Box ¹ | 777643-01 | 1 | 295.00 | BNC connector box |
| | NI SH68-68-EP, Shielded Cable, 1 m ¹ | 184749-01 | 1 | 105.00 | Cable connecting the PCI-60136E and BNC-2110 |
| 3 | Omega DP25B-S-A Strain Gauge Meter | DP25B-S-A | 2 | 650.00 | Strain meter with 0-10 volt analog output |
| | Omega LC-201 Load Cell | LC201-25 | 1 | 485.00 | 25 lb strain-type load cell |
| | Omega BCM-1 Strain Gauge Bridge | BCM-1 | 1 | 68.00 | Strain gauge completion bridge |
| 4 | Schaevitz 3000 DC-EC LVDT | 3000 DC-EC | 1 | 454.00 | Plus/minus 3 inch stroke |
| | Schaevitz LVDT power supply | PSD 4-15 DC | 1 | 145.00 | 4-15 volt DC LVDT power supply |
| | Schaevitz LVDT mounting block | 04560950-000 | 2 | 48.00 | Mounting block for E series LVDT |
| 5 | HSI Size 23 Non-Captive Linear Actuator | 57F42-05-002ENG | 1 | 118.00 | Maximum thrust up to 25 lb with 10 inch lead screw |
| 6 | NEESPOP Linux Server | | 1 | 2,500.00 | |
| 7 | Telepresence Linux Server | | 1 | 2,000.00 | |
| | Axis 2401+ Video Server ² | | 1 | 800.00 | |
| | Sony EVI-D100 PTZ camera ² | | 1 | 900.00 | |
| 8 | Broadware Streaming Server Software for RH Linux | | 1 | 2,000.00 | |
| | Matlab License | | 1 | 500.00 | North America Academic Price |
| | Labview Full Package | 776671-03 | 1 | 498.75 | North America Academic Price |
| | Labview Internet Developers Toolkit | 777343-01 | 1 | 123.75 | North America Academic Price |
| | NI Motion Assistant SW for Motion Control Programming | 778553-01 | 1 | 198.75 | North America Academic Price |
| 9 | Material and Labor Cost for Machining | | | 3,000.00 | The price is estimated based on the rate at UIUC, single actuator version |
| Total: | | | | \$ 20,274.25 | |

1. National Instruments provides 10% discount to educational institution on hardware purchase.

2. The Axis 2401+ video server and Sony EVI-D100 PTZ camera can be replaced by an Axis 2130 network PTZ camera which has a built in video server. The cost is about \$1600.